

ORTSTEIL POUCH

Musterhaus



696m² ①

901m² ②

729m² ③

999m² ④

1073m² ⑤

1087m² ⑥

1091m² ⑦

1065m² ⑧

verkauft

Fischergasse

untere Fischergasse

Großer
Goitzschensee

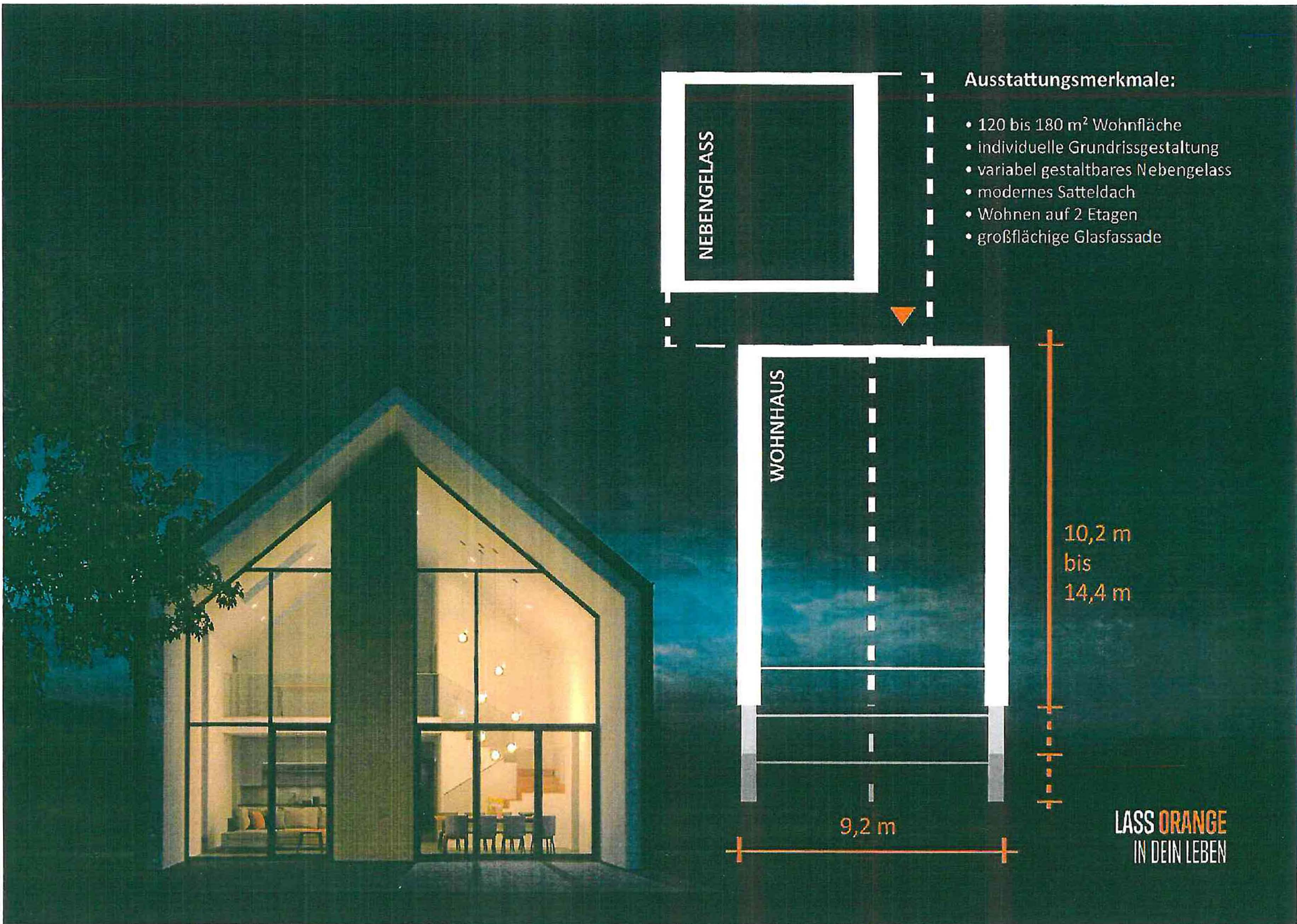

NEBENGELASS

Ausstattungsmerkmale:

- 120 bis 180 m² Wohnfläche
- individuelle Grundrissgestaltung
- variabel gestaltbares Nebengelass
- modernes Satteldach
- Wohnen auf 2 Etagen
- großflächige Glasfassade

WOHNHAUS

10,2 m
bis
14,4 m

9,2 m

LASS ORANGE
IN DEIN LEBEN

0
1
2
3
4
5m

12,9 m

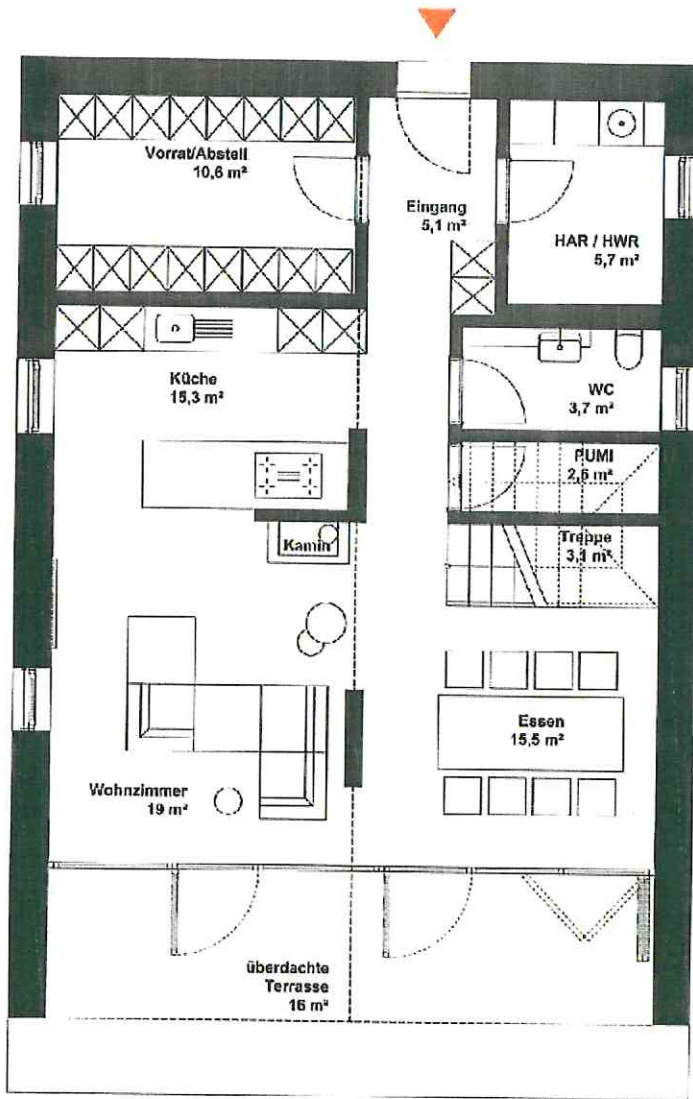

Erdgeschoss 80,5 m²
zzgl. 16 m² überdachte Terrasse

9,2 m

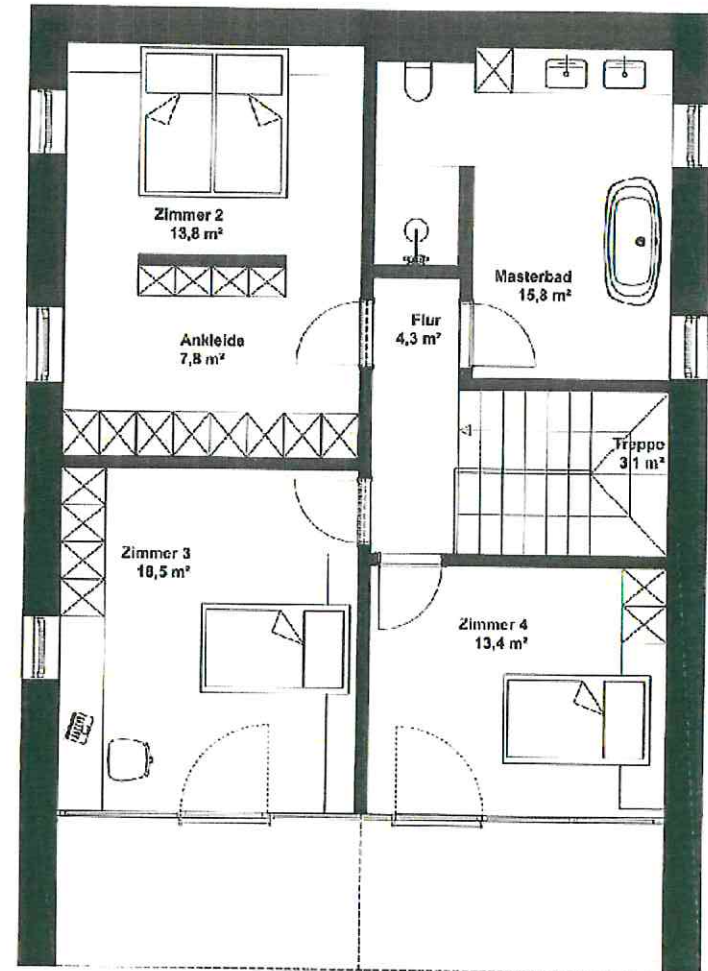

Obergeschoss 76,7 m²

Beispielgrundriss 157,2 m²

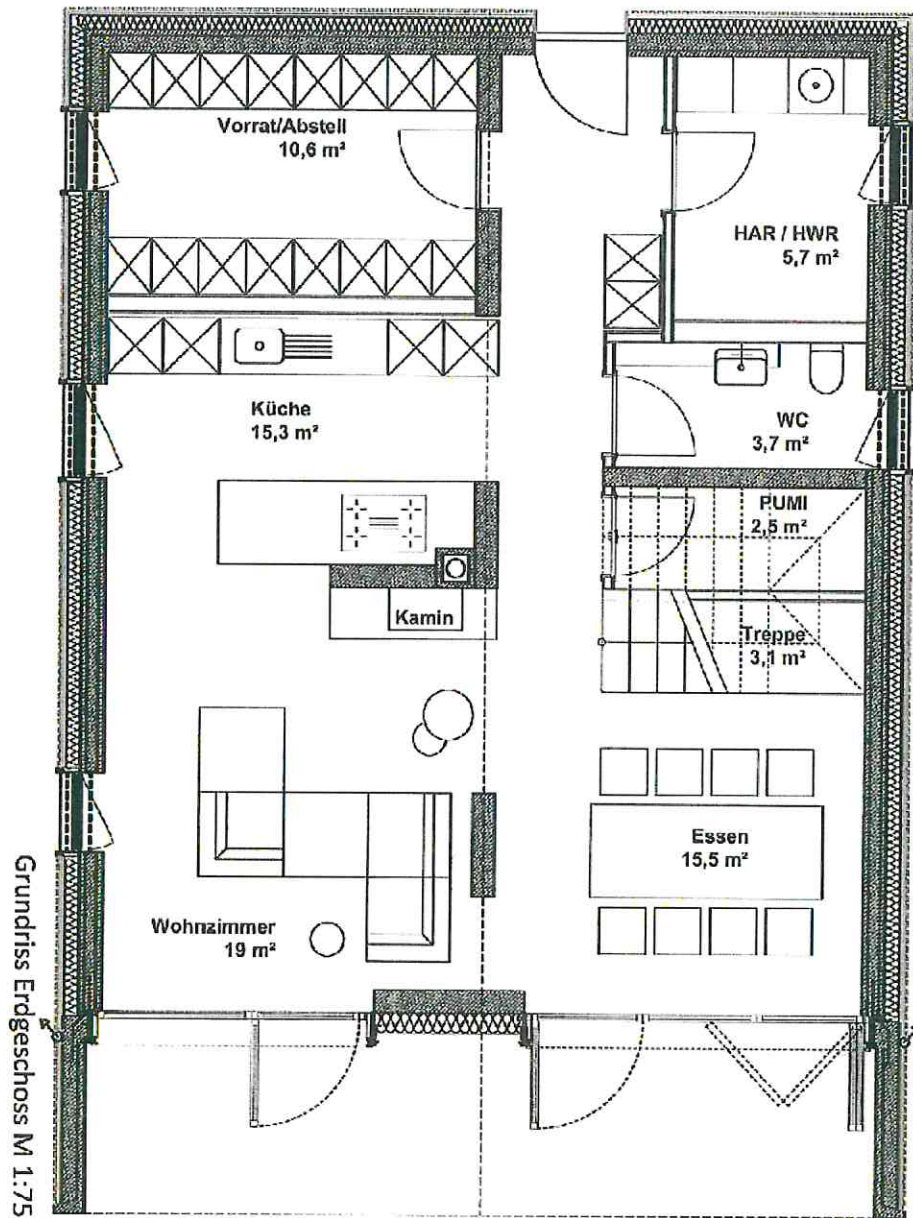

BEISPIELGRUNDRISS 157,2m²

ohne Luftraum, mit Balkon

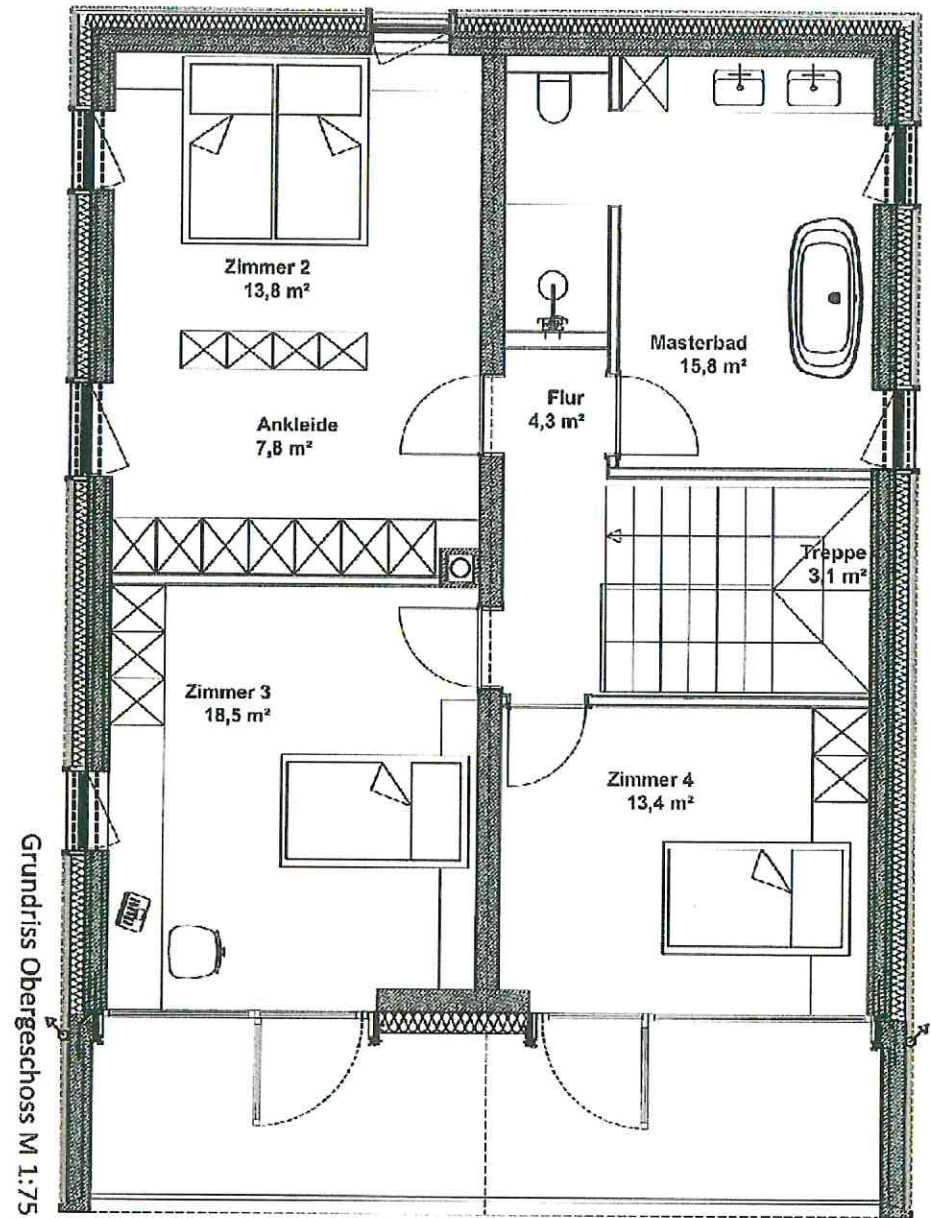

Grundrissvariante **BALKON**

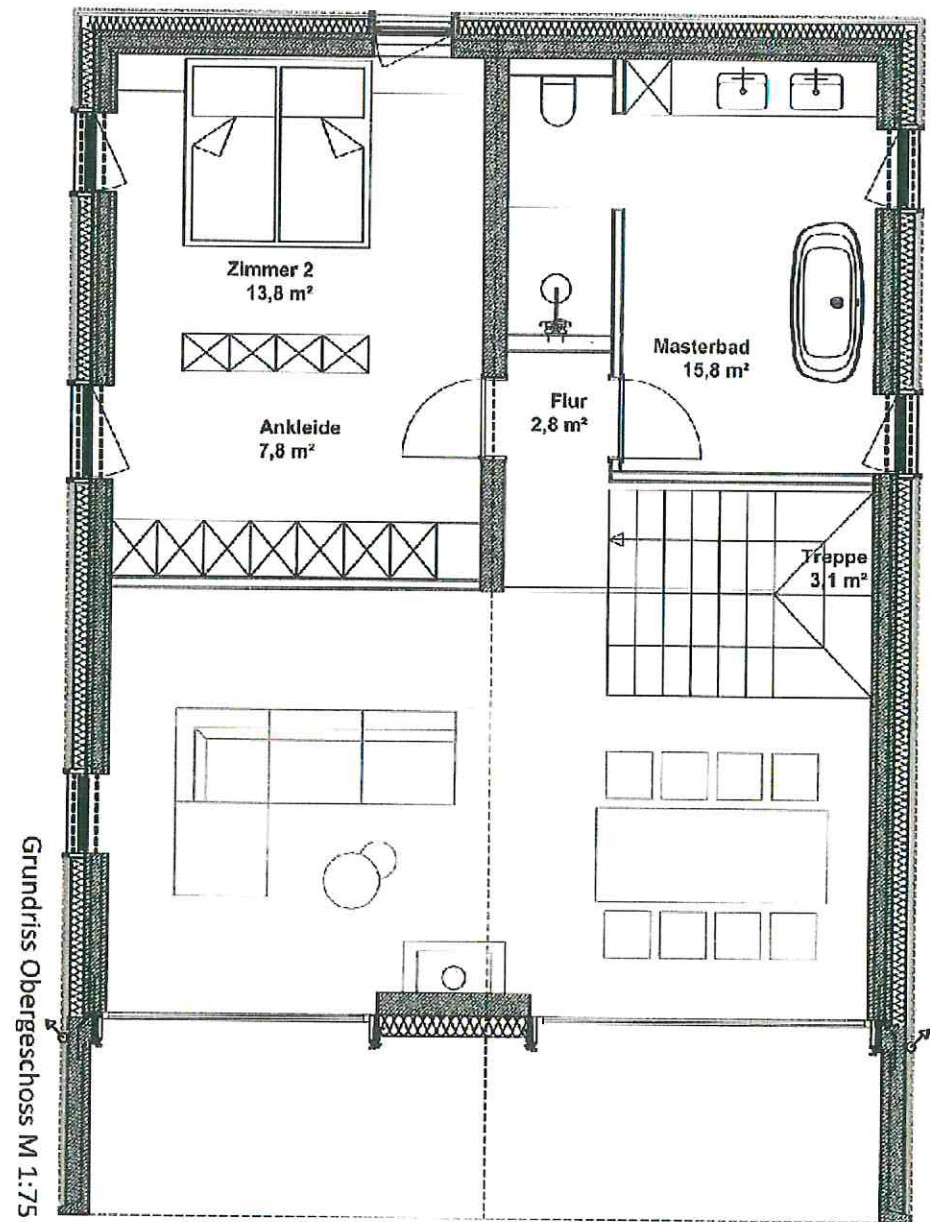
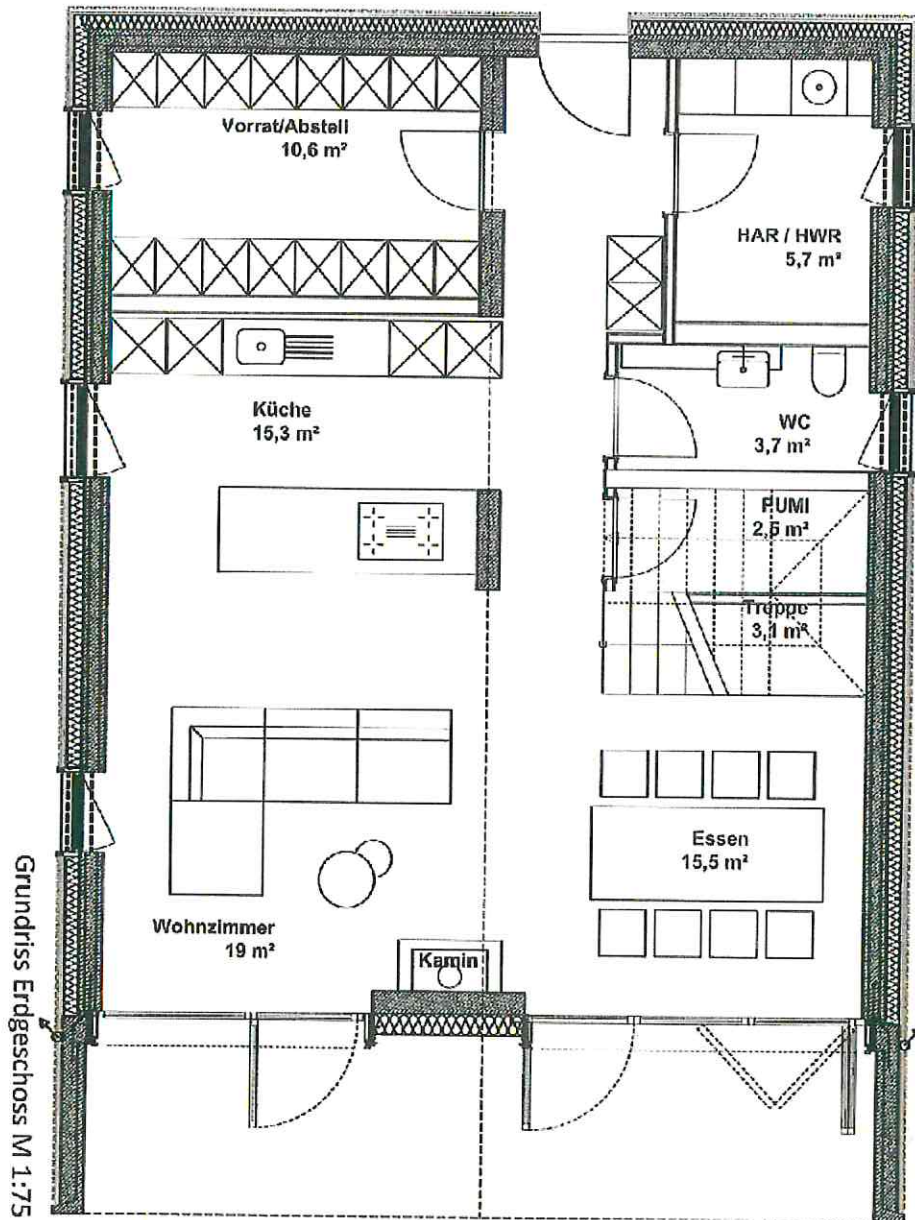

BEISPIELGRUNDRISS 123,8m²

mit Luftraum, ohne Balkon

Grundrissvariante LUFTRAUM

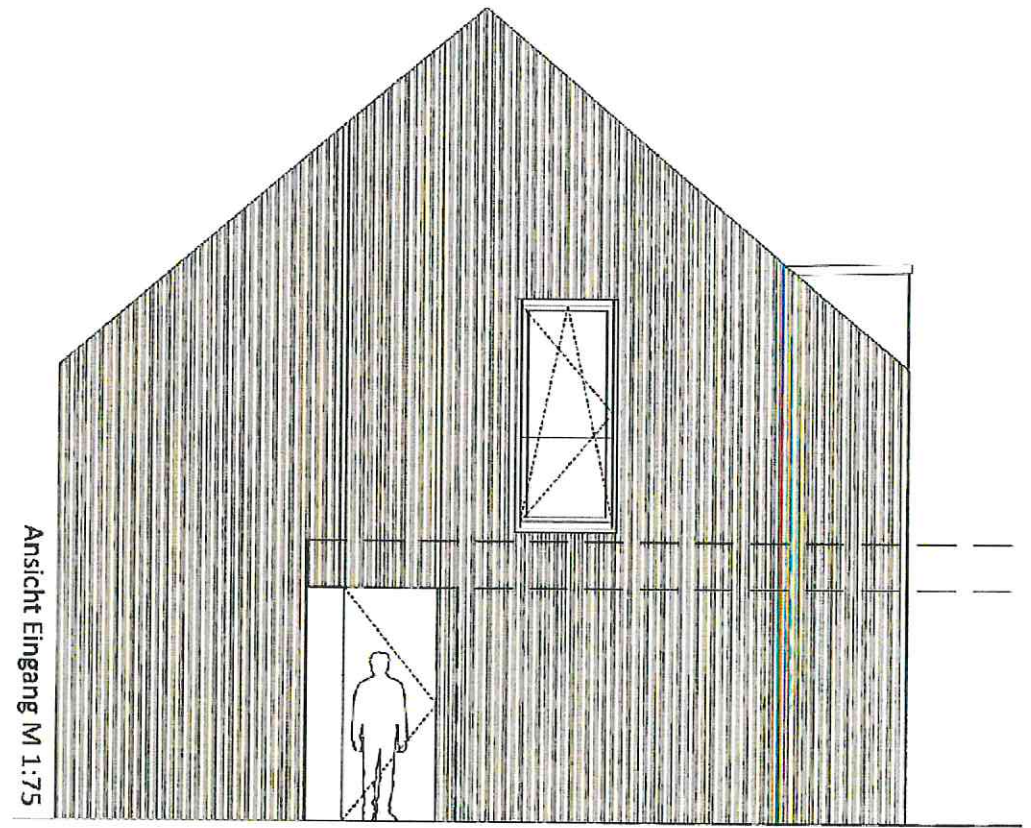

Ansichten **Giebel Eingangsbereich**

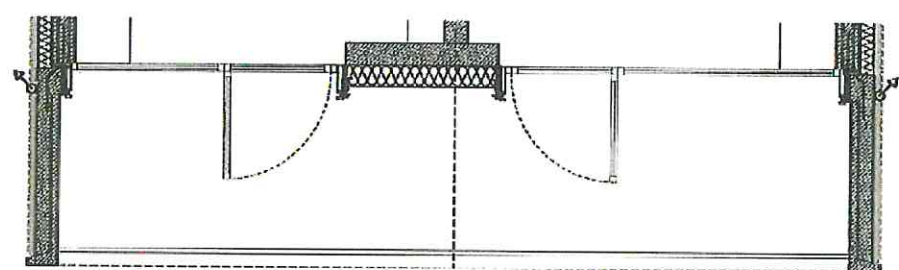
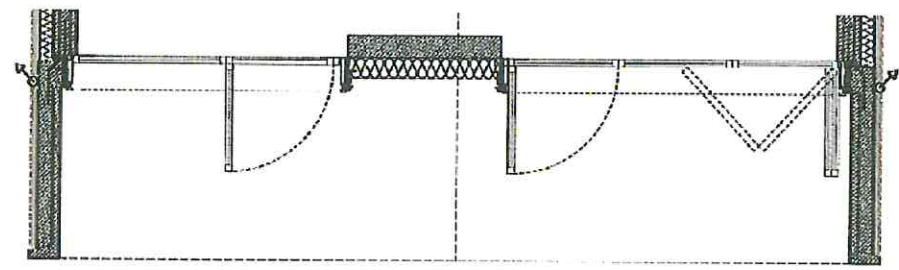
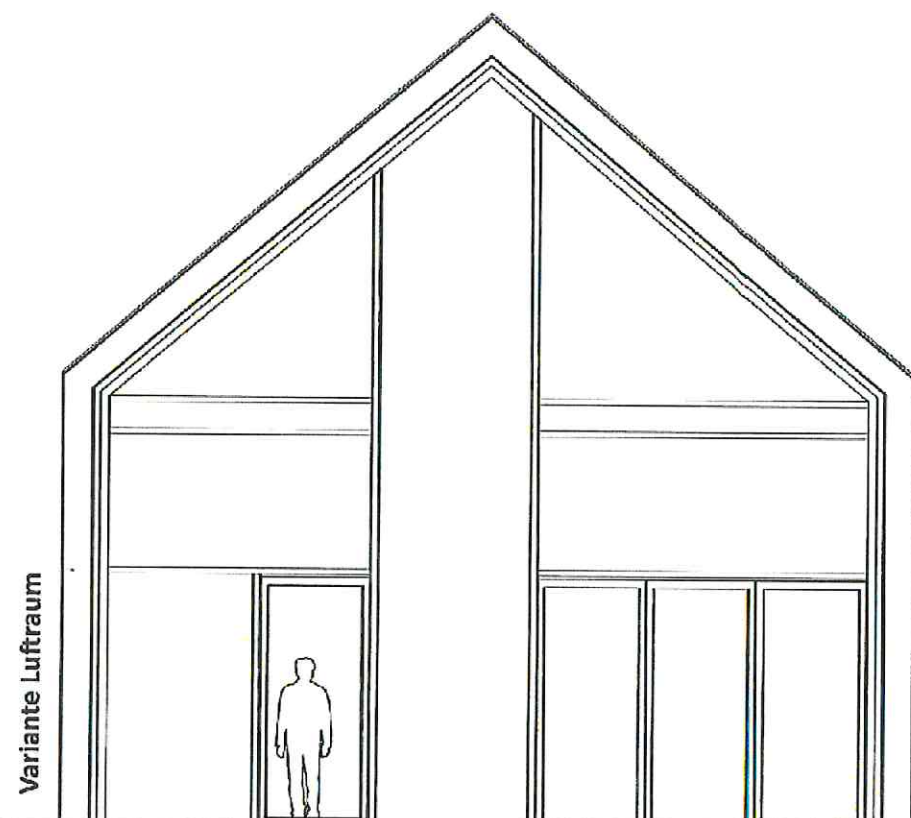
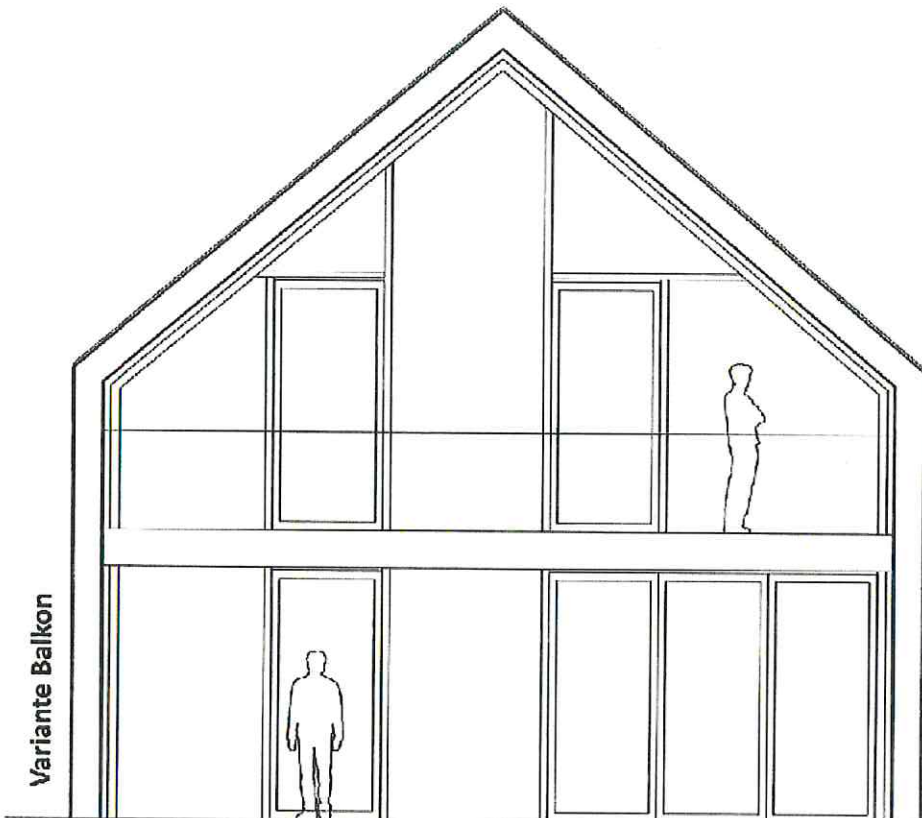

Ansichten Giebel Gartenseite

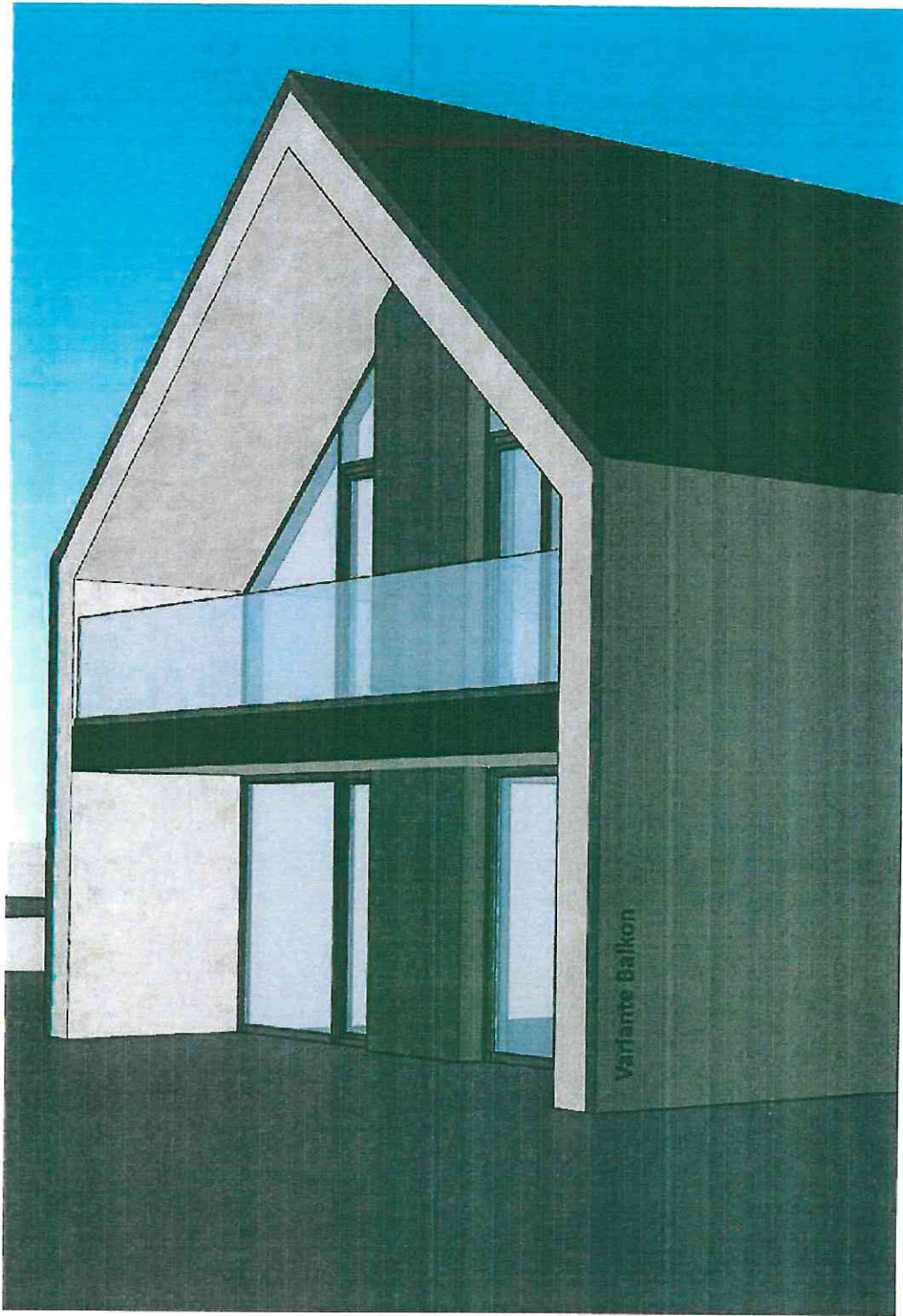

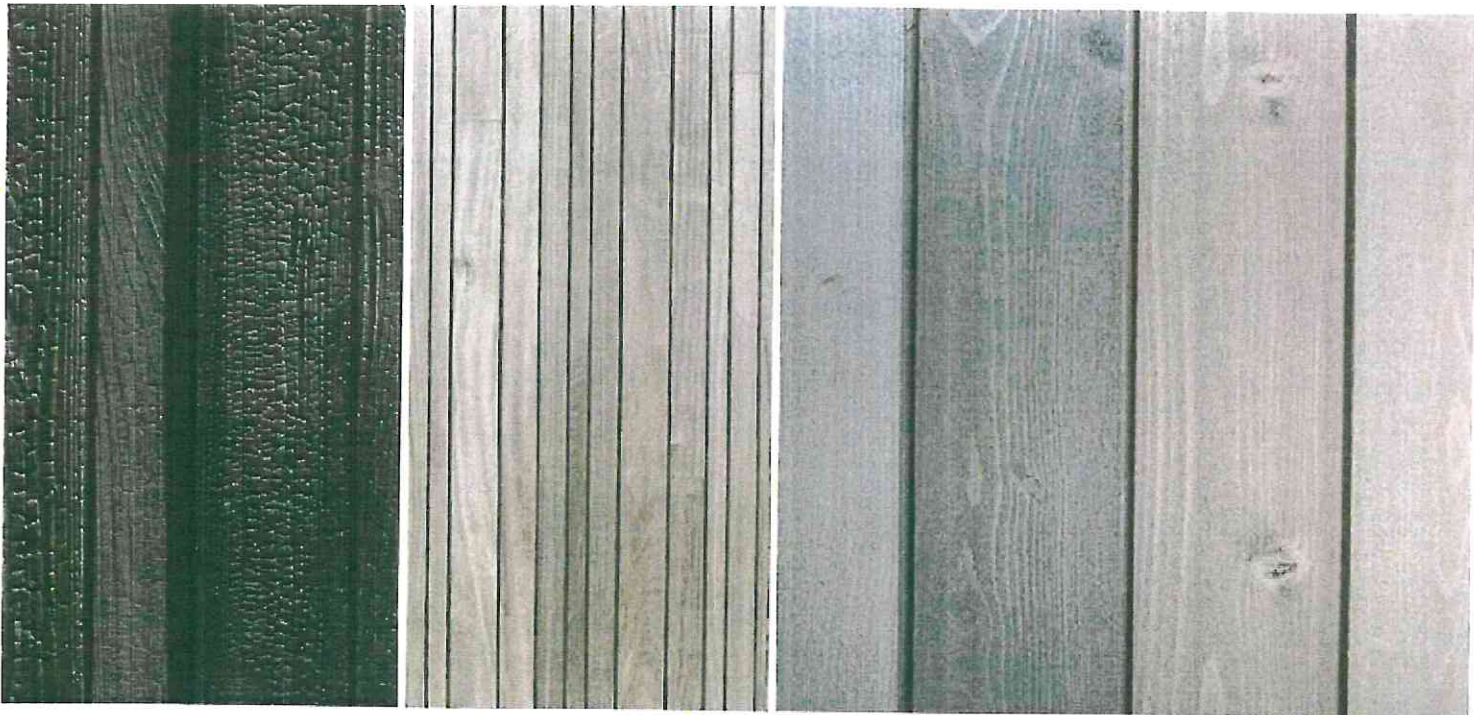

Yakisugi

Lärche vergraut

Weißtanne vorvergraut,
verschiedene Farben

**Holz-Vorhangfassade
an straßenseitigem Giebel und den Traufseiten**

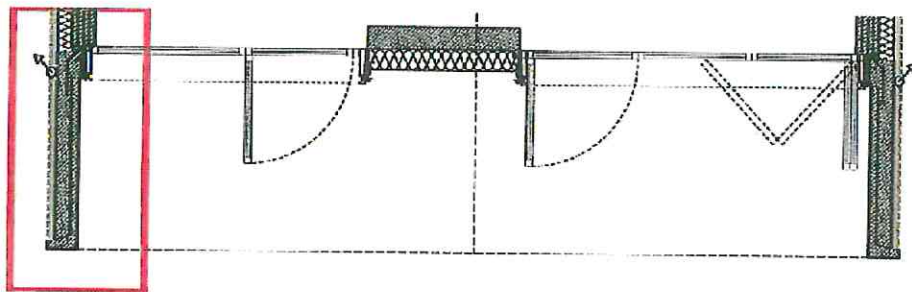

Detail D1

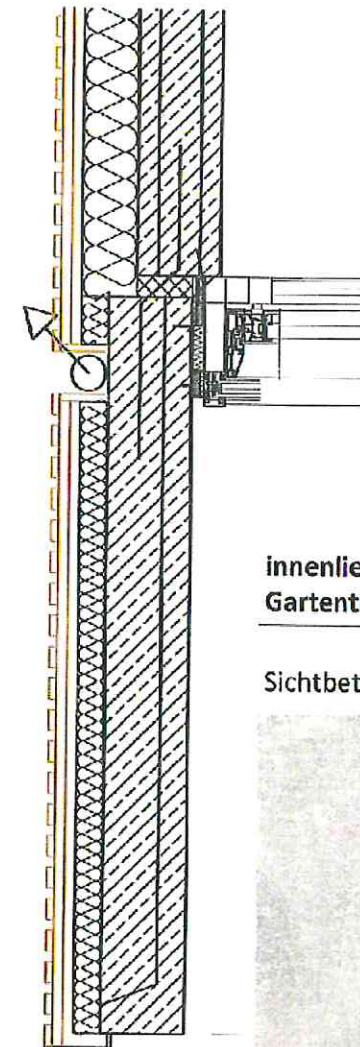

innenliegende Fassade
Gartenterrasse

Sichtbeton

Detail D1
M 1:20

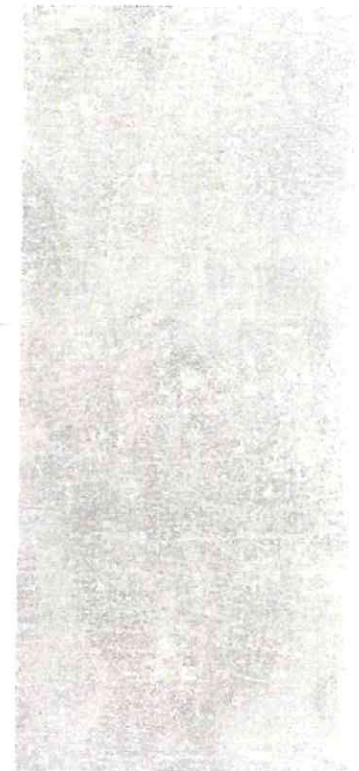

Fassadenoberflächen

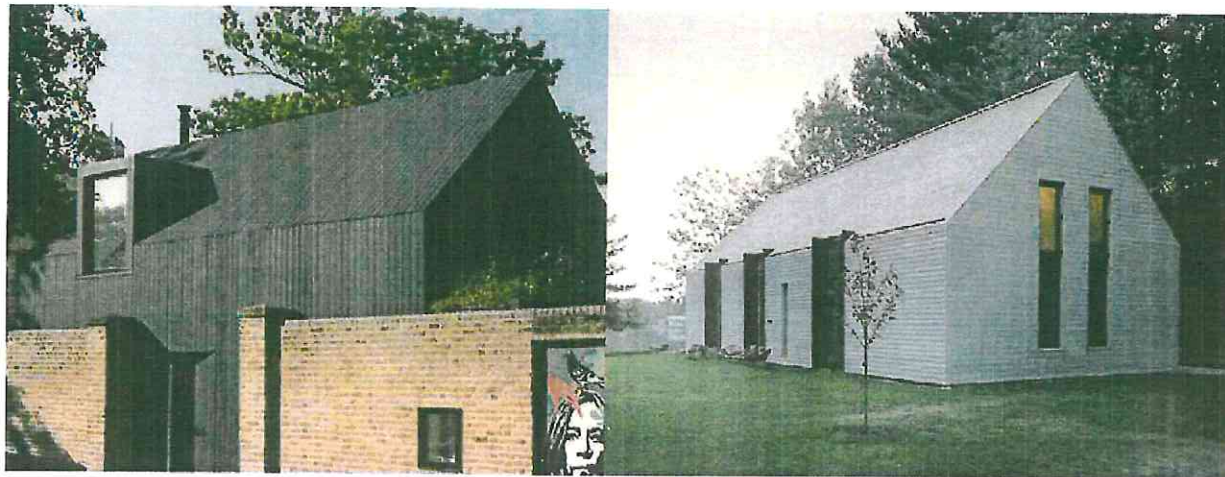
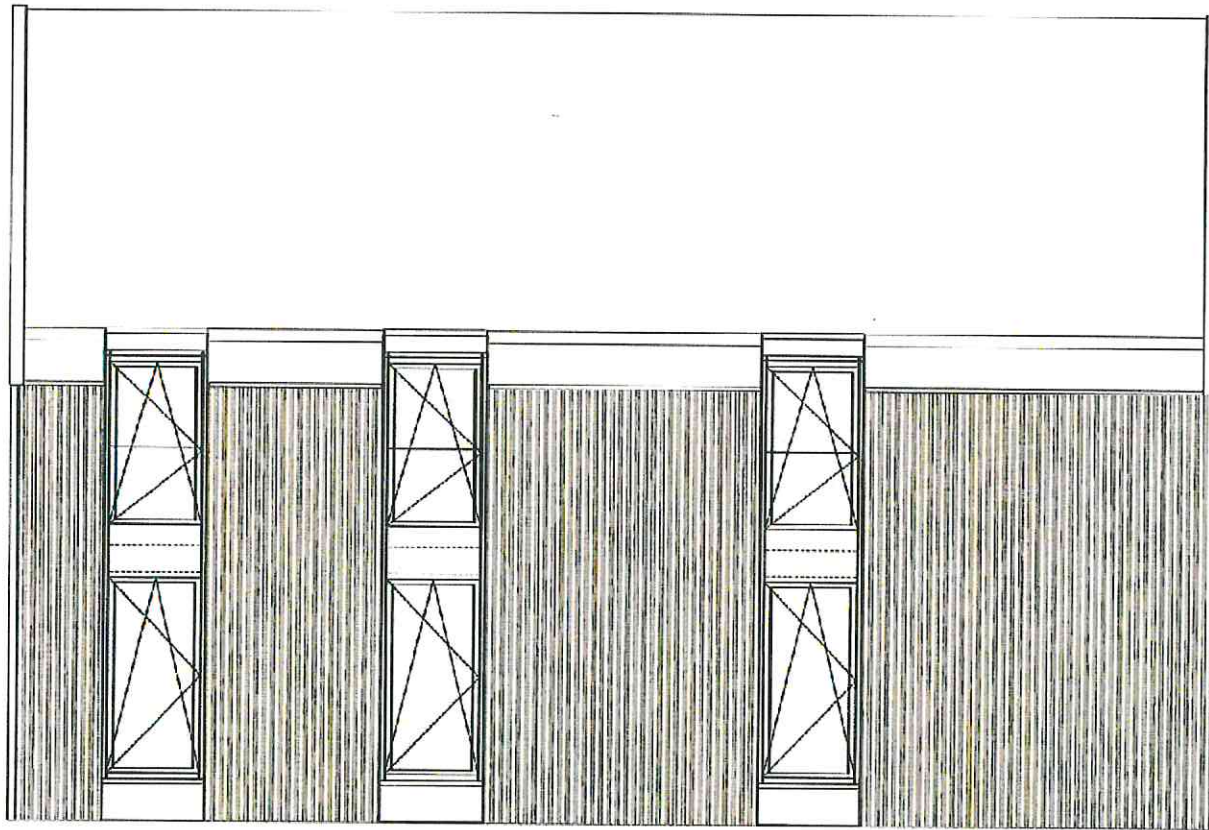

Ansichten Traufseiten

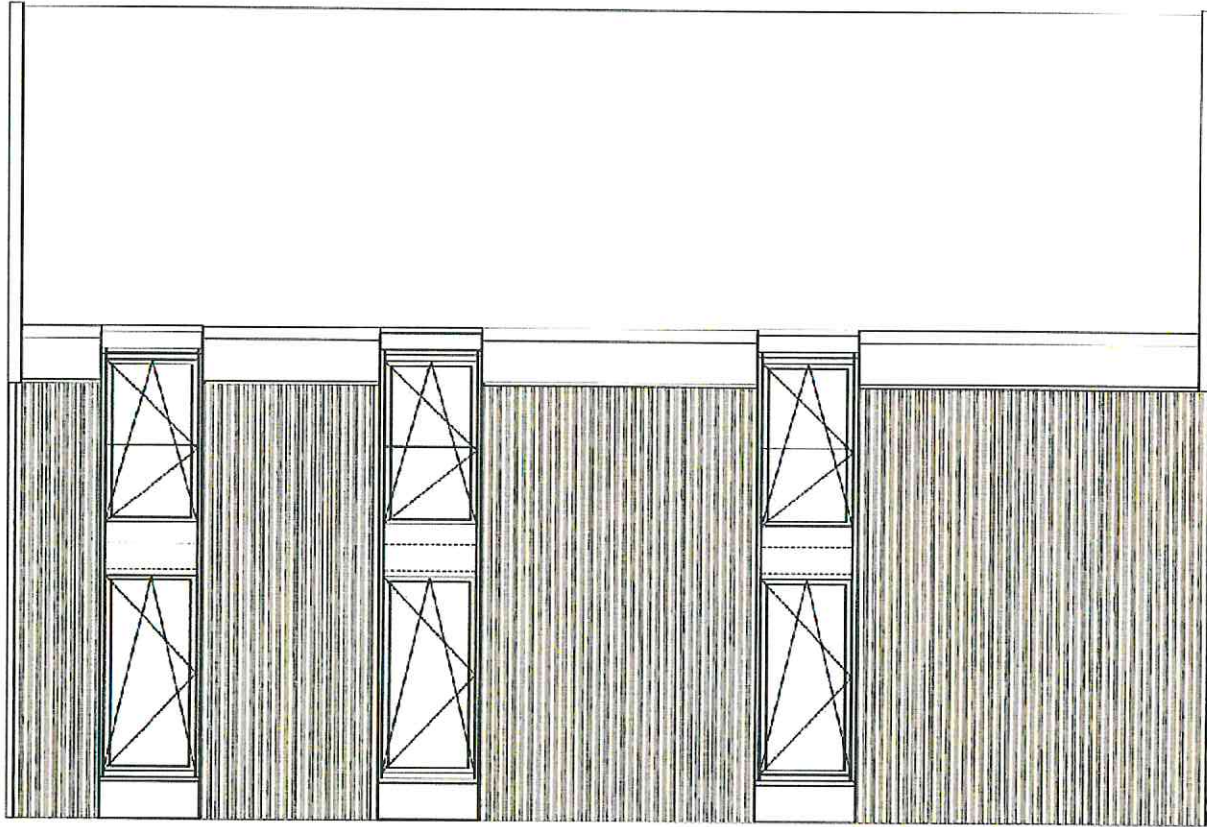

Variante
vertikale, eingerückte Fensterbänder

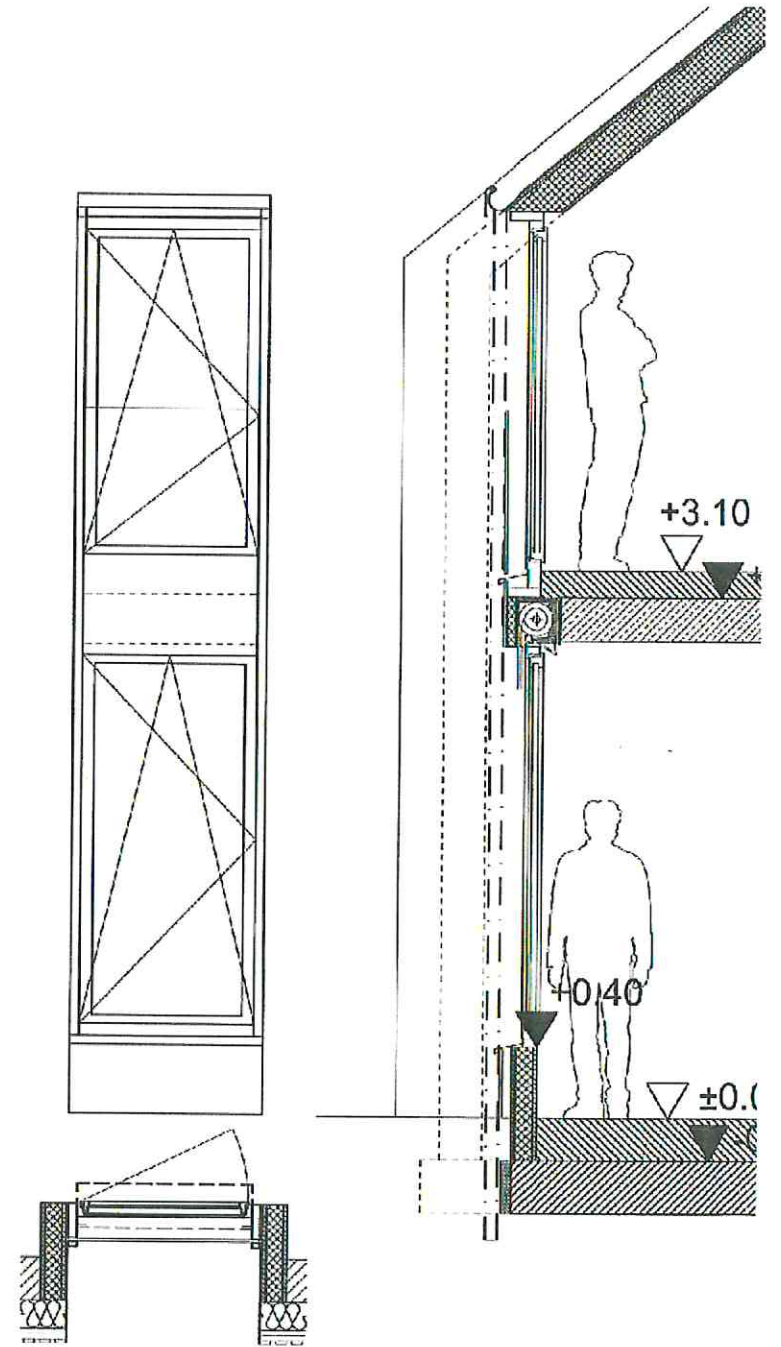

Traufseiten Fenster 1

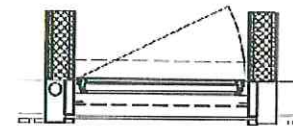
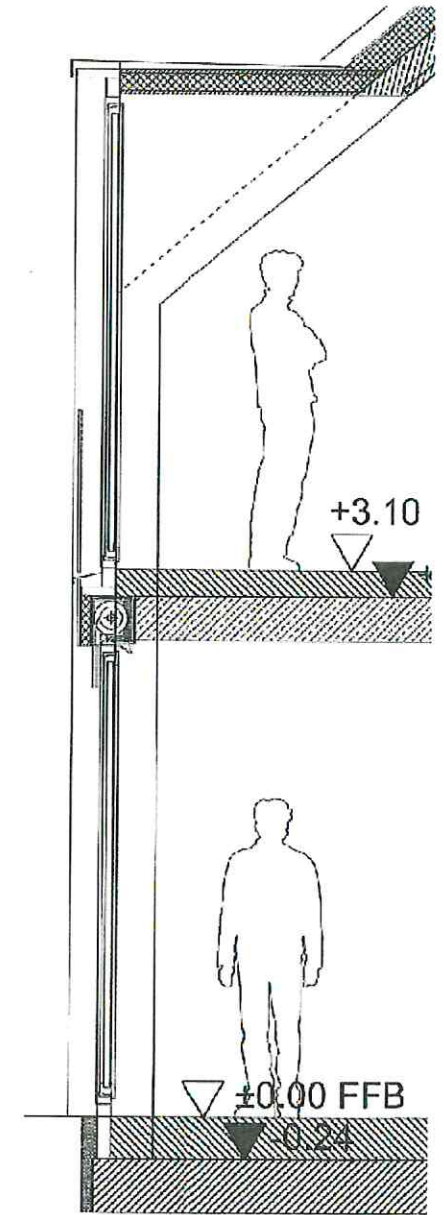
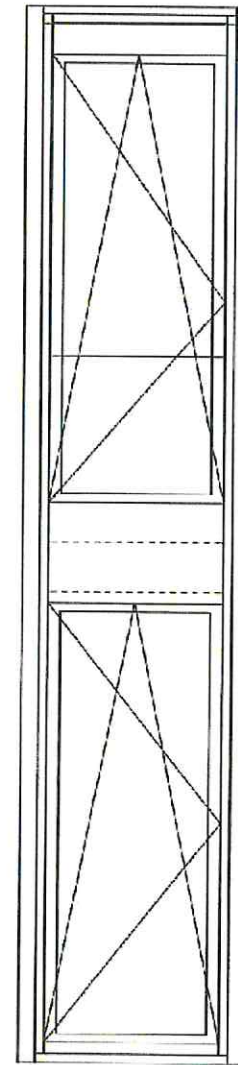
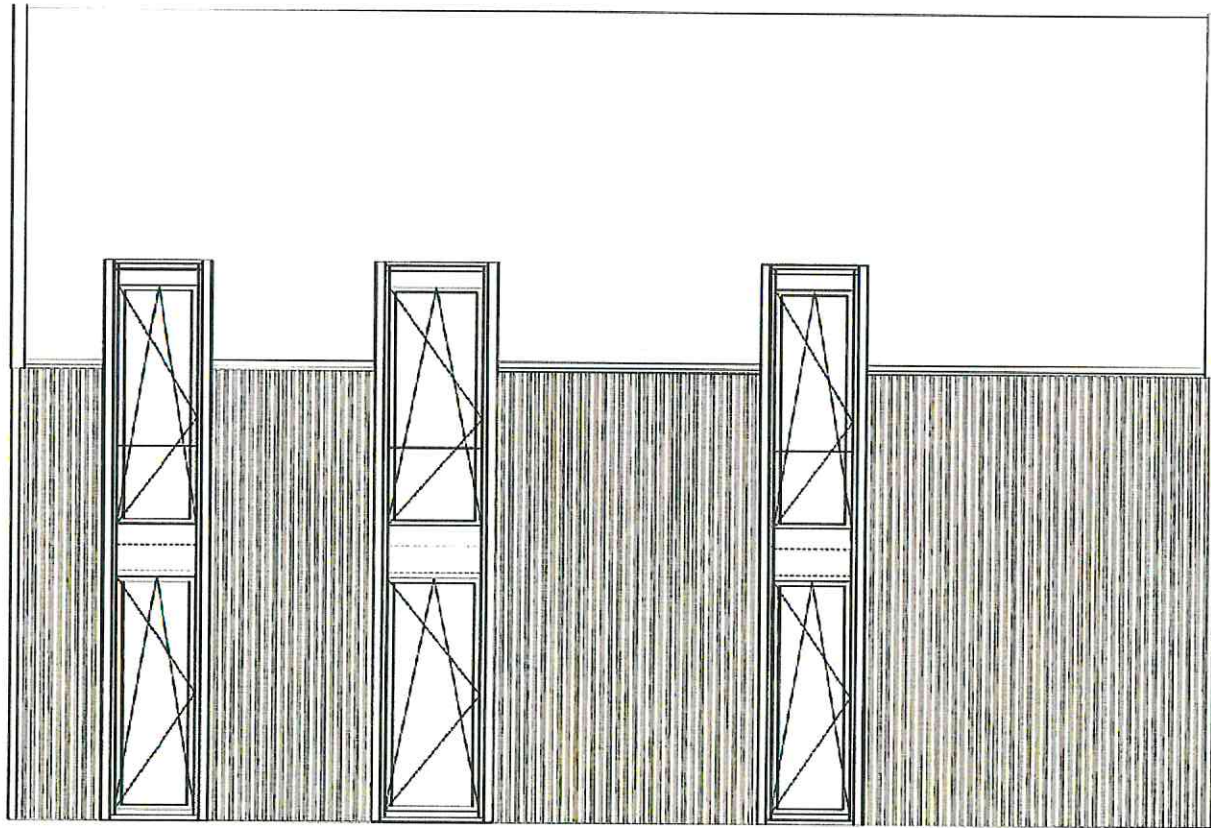

Traufseiten Fenster 2



Variante
Seitenfenster als Gaube ausgebildet

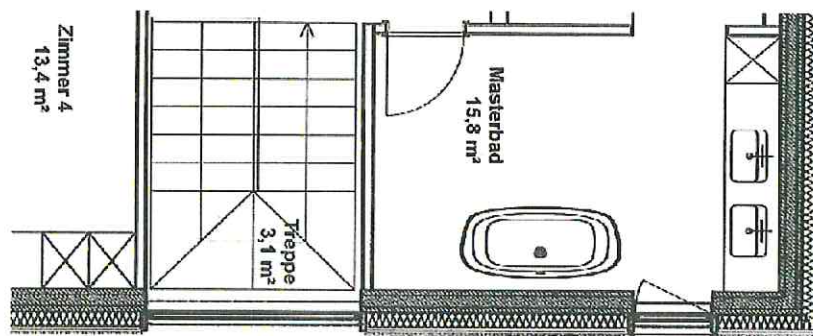
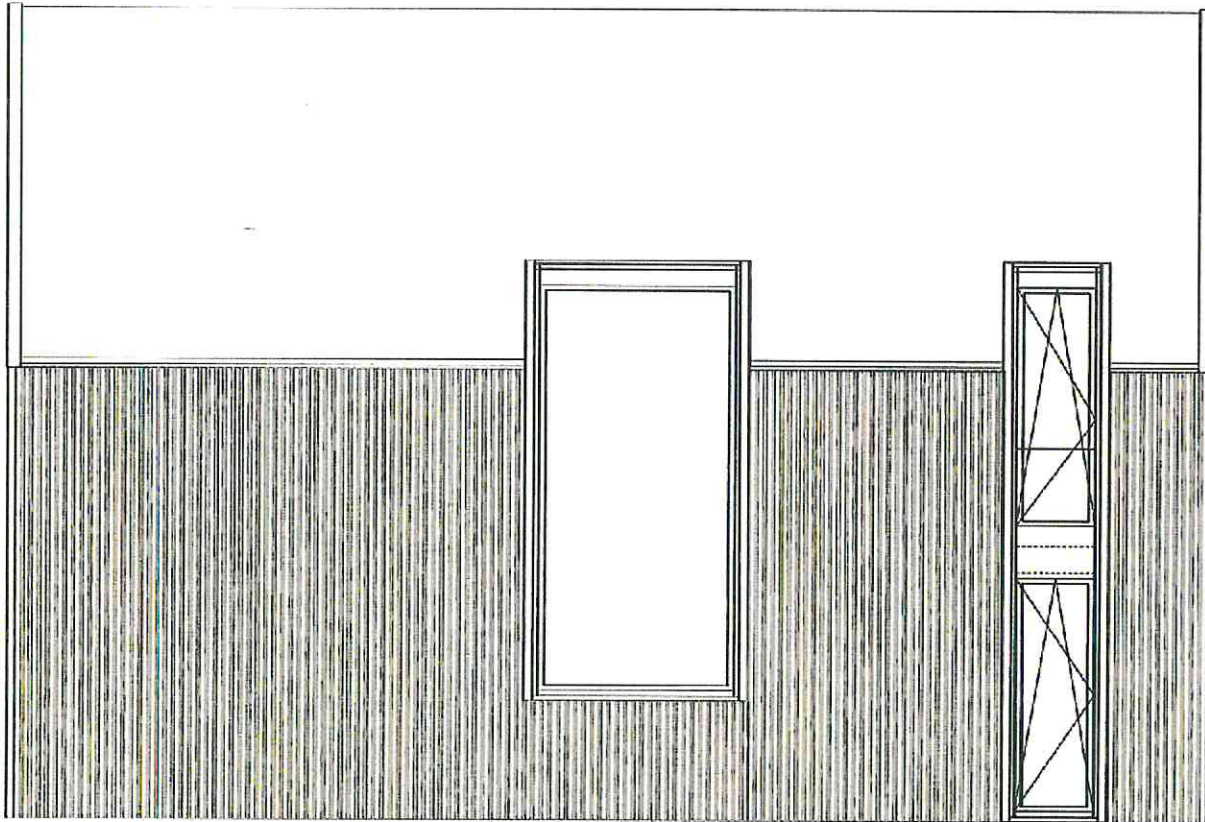

Variante
große Gaube im Bereich der Treppe

Taufseiten Fenster 3

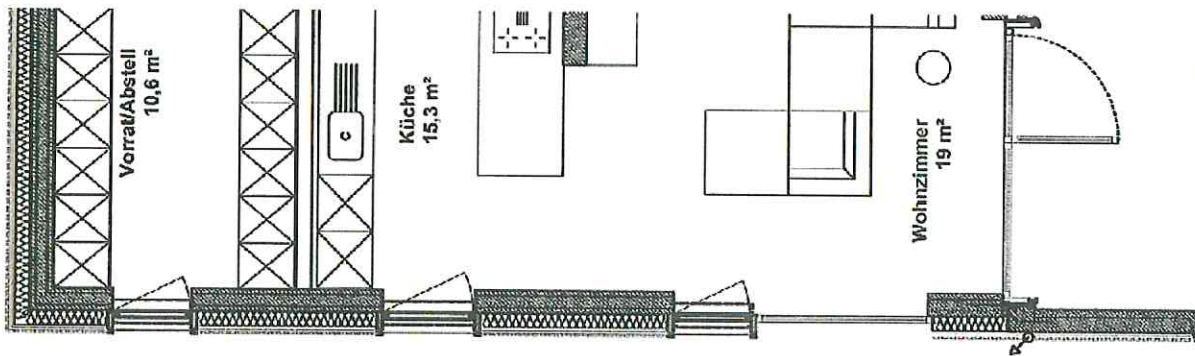
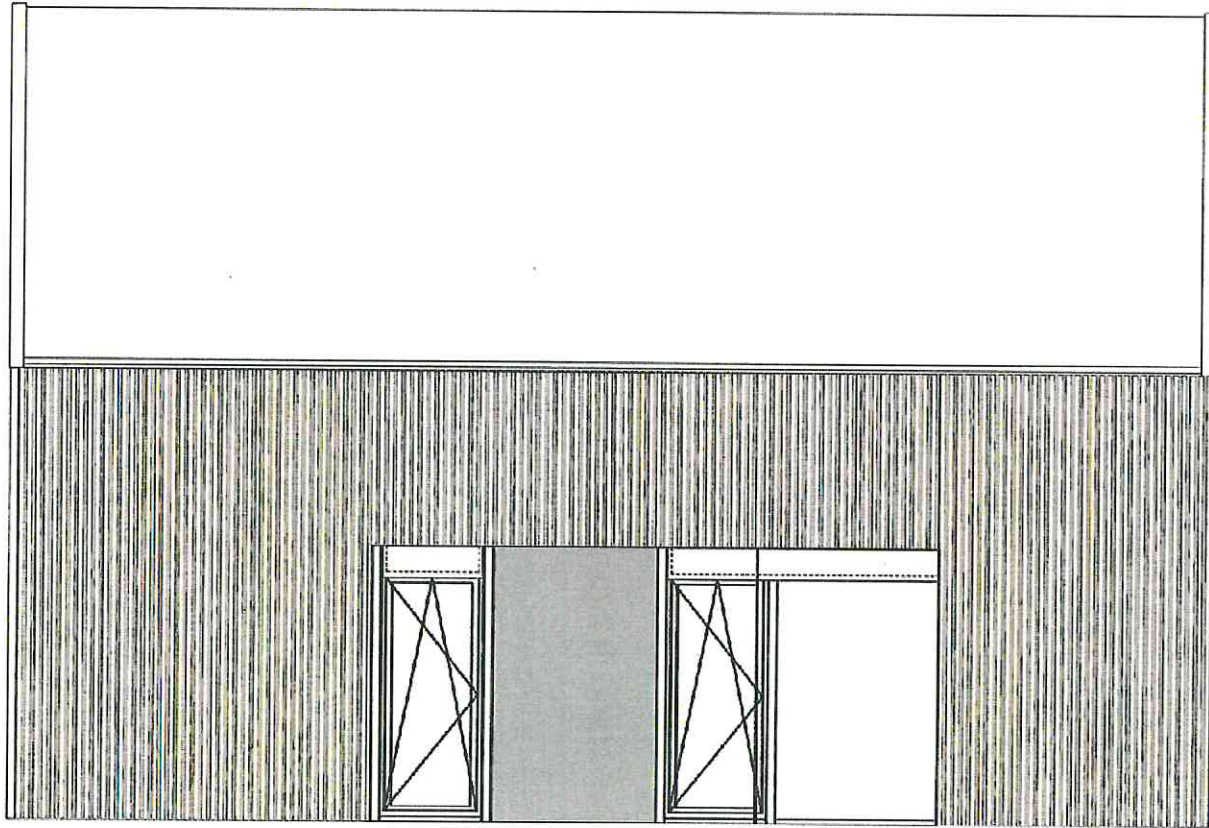

Variante
großzügige Fassadenöffnung

Taufseiten Fenster 4

Variante **1**

vertikale, eingerückte Fensterbänder



Variante 2
Seitenfenster als Gaube ausgebildet



Variante **3**
große Gaube im Bereich der Treppe



Variante 4
großzügige Fassadenöffnung





dänisches Leistenpappdach



Stehfalz Blechdach

Deckbeläge

Dach

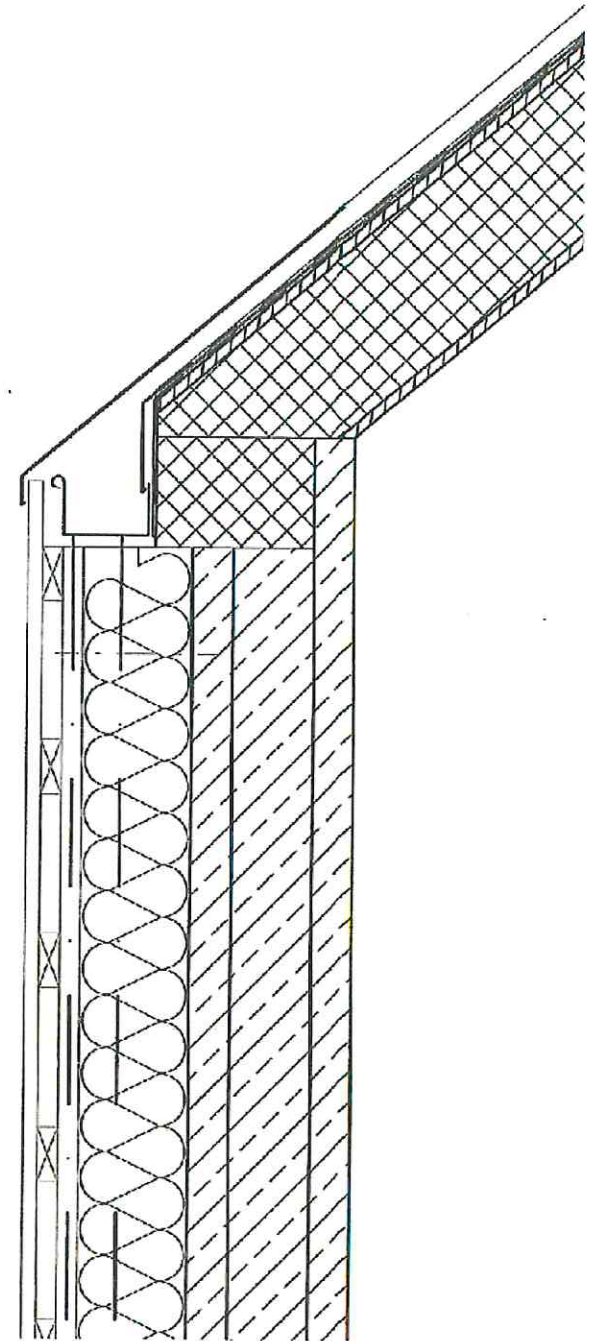



Kastenrinne verdeckt
Fallrohr bündig mit Fassade

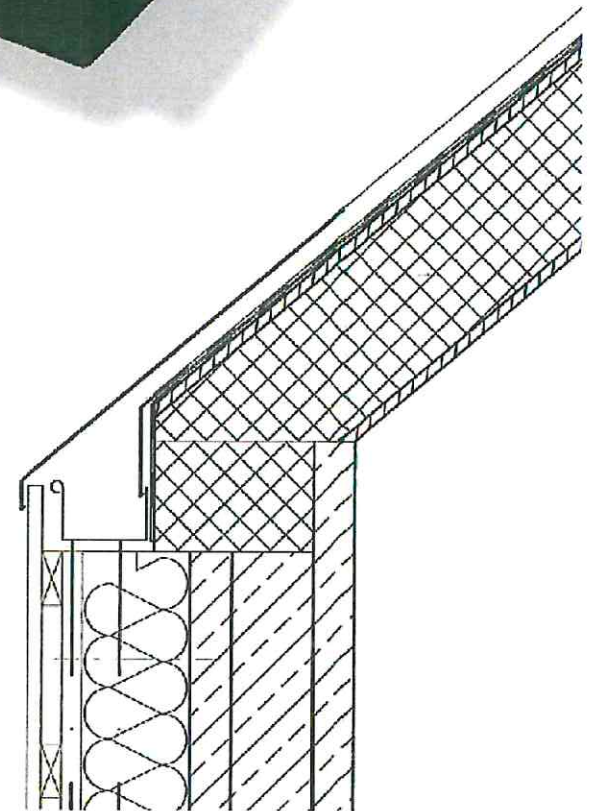
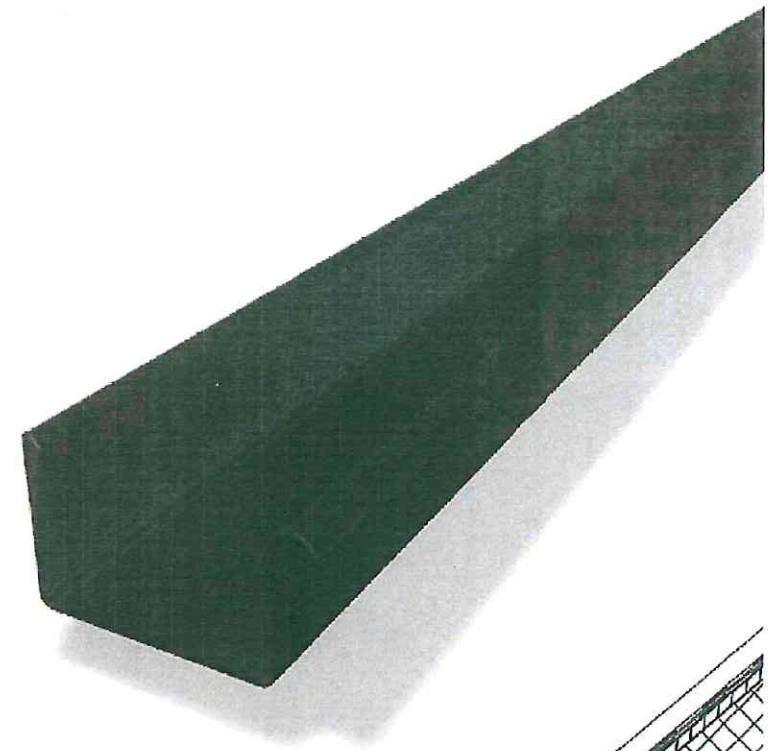

Dach

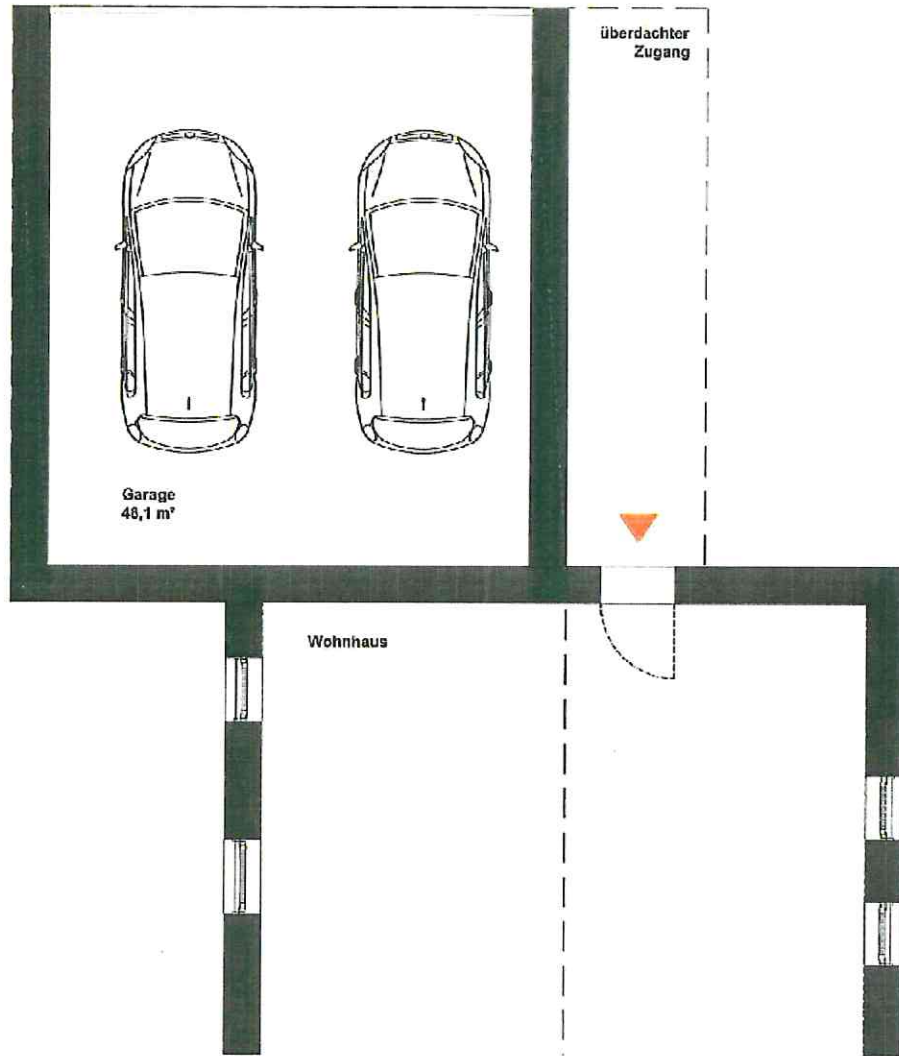

Beispielgrundriss Nebengelass

Garage

0 1 2 3 4 5m

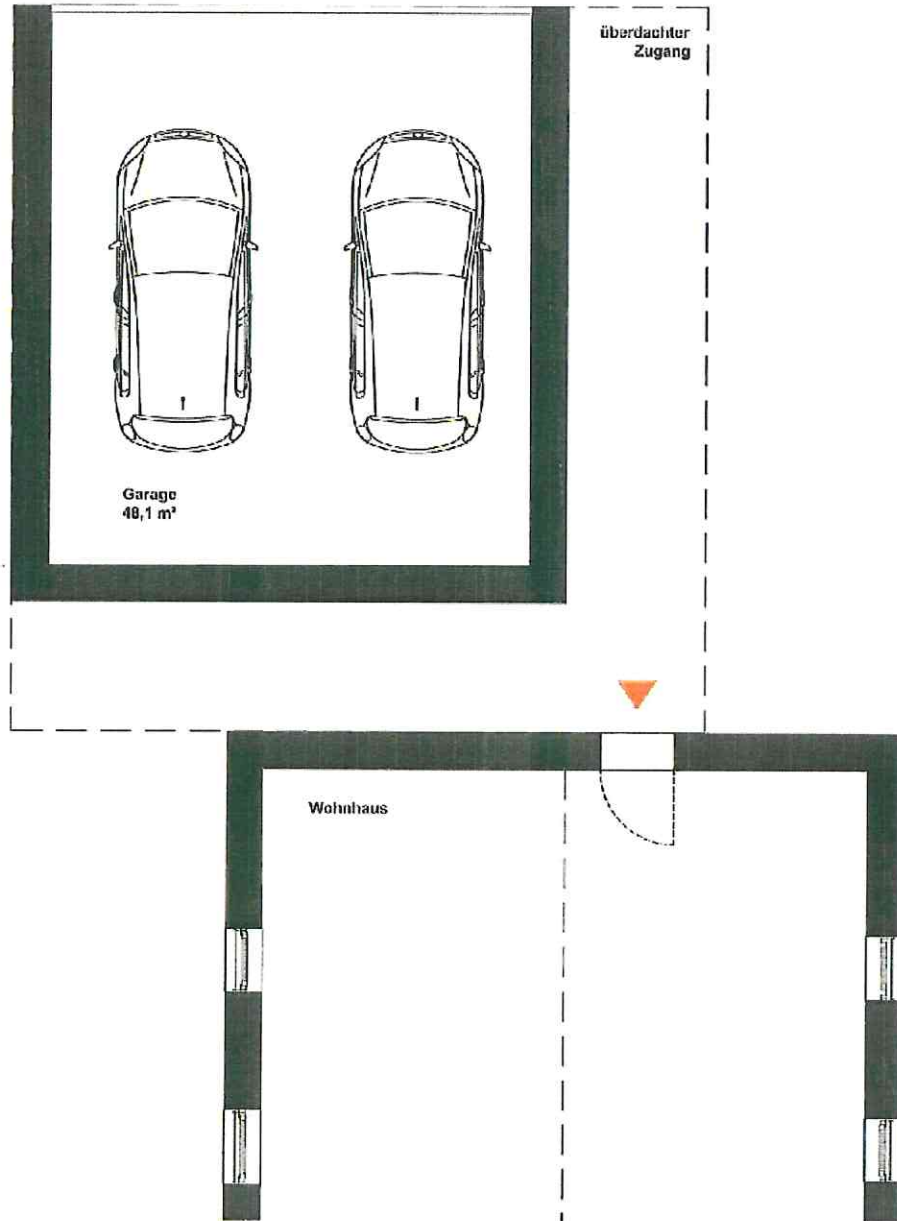

Beispielgrundriss Nebengelass

Garage mit überdachtem Gartenzugang

0 1 2 3 4 5m

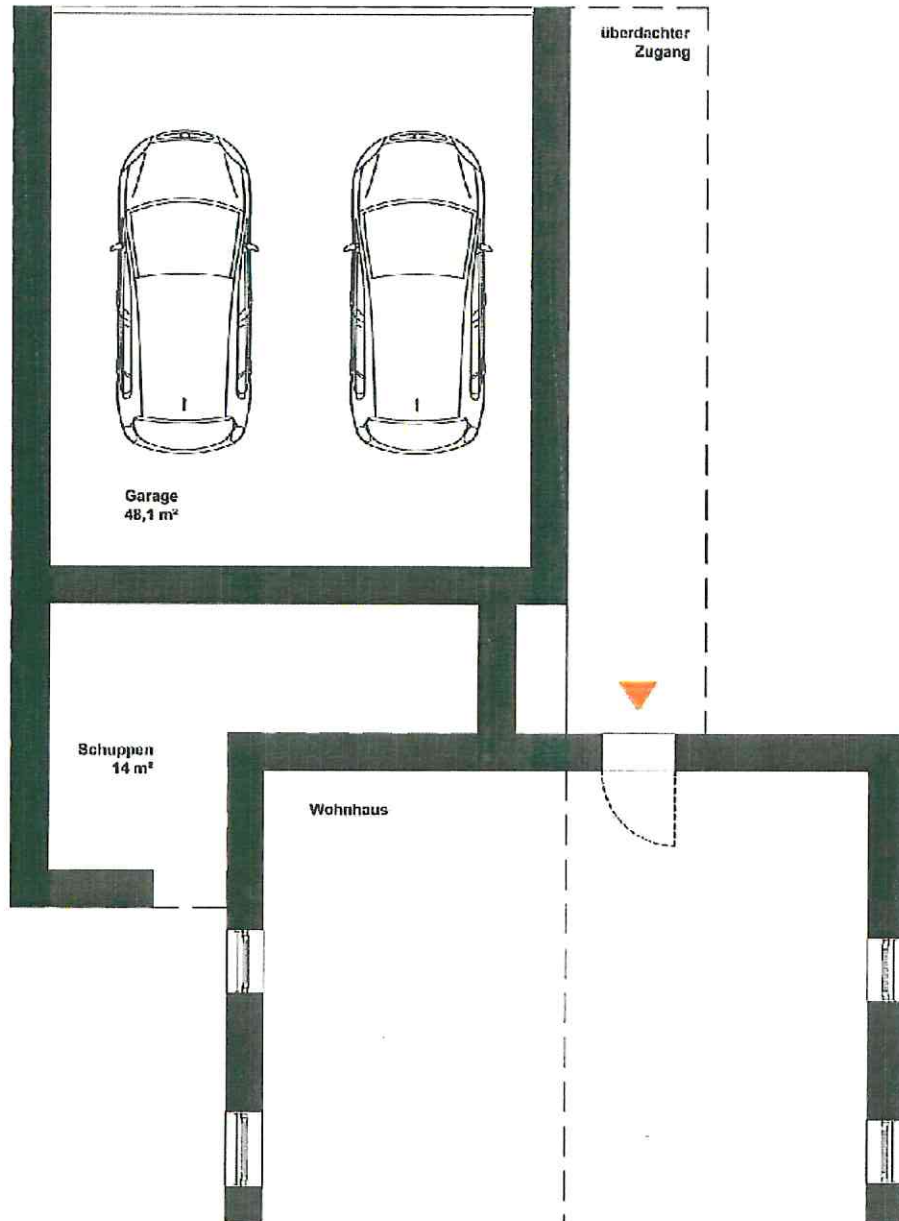

Beispielgrundriss Nebengelass

Garage mit Schuppen



LASS ORANGE
IN DEIN LEBEN

Wohnen mit Seeblick.

Neun außergewöhnliche Grundstücke direkt am See erwarten Sie als neue Eigentümer. Individuell geplant und an Ihre Bedürfnisse angepasst, kann auf 110 bis 200 m² Wohnfläche hier Ihre Wunschimmobilie entstehen.

Ansprechpartner:

Herr Lutz Blaschke
Tel +49 (0) 34 94 - 37 90
Mail info@blaschke-immobilien.de

NEBENGELASS Beispielgrundriss

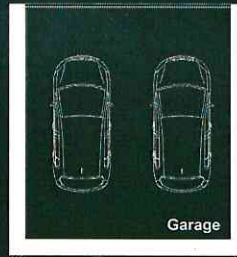

Garage

Nebengelassmöglichkeit

Ausstattungsmerkmale:

- individuelle Grundrissgestaltung
- variabel gestaltbares Nebengelass
- modernes Satteldach
- Wohnen auf 2 Etagen
- einheitliche Fassadengestaltung mit großflächigem Glasgiebel und vertikalen Holzlamellen

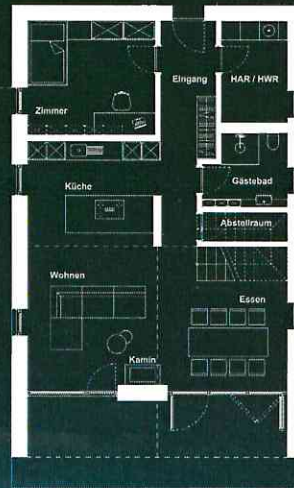

ERDGESCHOSS
Beispielgrundriss

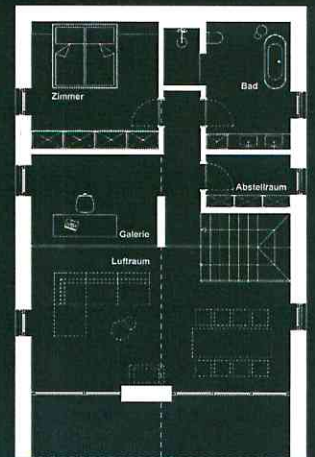

OBERGESCHOSS
Beispielgrundriss



blaschke
immobilien
www.blaschke-immobilien.de